



Electrische Kettingtakel SG.DTS / Electric Chain Hoist SG.DTS

Eigenschappen

- » Robuuste aluminium behuizing.
- » Geschikt voor een breed scala aan industriële toepassingen.
- » Wartel lasthaak met veiligheidsklep.
- » Eenvoudig te demonteren voor onderhoudsdoeleinden.
- » Met SIEMENS besturingssysteem.
- » Permanent gesmeerde transmissie, zorgt voor een soepele en stille werking.
- » Geleverd met bedieningsschakelaar, voedingskabel en kettingbak.
- » Voldoet aan de Machinerichtlijn 2006/42/EG. Geleverd met testcertificaat, CE-conformiteitsverklaring en gebruiksaanwijzing.

Features

- » Robust aluminium housing.
- » Suitable for a wide range of industrial applications.
- » Swivel load hook with safety latch.
- » Easy to disassemble for maintenance purposes.
- » Control system with SIEMENS relais.
- » Permanently lubricated transmission, ensures smooth and quiet operation.
- » Supplied with control switch, power cable and chain container.
- » Complies with the Machinery Directive 2006/42/EC. Supplied with test certificate, CE declaration of conformity and operating instructions.



optioneel / optional



SG.0.DTS

Specificaties / Specifications

Artikel nummer Article code	Capaciteit Capacity	Hijssnelheid Lifting speed	Hijsketting Load chain	Parten Chains falls	Energie verbruik Power output	Netto gewicht Net weight	Extra gewicht Extra weight
	ton	m/min *	Øxmm		kW	kg	kg/m
SG.0.DTS.00251	0.25	7	5 x 15	1	0.45	42	0.7
SG.0.DTS.00252	0.25	7/2.3	5 x 15	1	0.45/0.15	50	0.7
SG.0.DTS.00501	0.5	7.6	6.3 x 19	1	0.9	43	0.9
SG.0.DTS.00502	0.5	7.6/2.5	6.3 x 19	1	0.9/0.3	51	0.9
SG.0.DTS.01001	1	5	8 x 24	1	1.1	45	1.5
SG.0.DTS.01002	1	5/1.7	8 x 24	1	1.1/0.37	57	1.5
SG.0.DTS.02201	2	2.5	8 x 24	2	1.1	51	3
SG.0.DTS.02202	2	2.5/0.85	8 x 24	2	1.1/0.37	64	3
SG.0.DTS.02101	2	5.3	10 x 30	1	3	94	2.2
SG.0.DTS.02102	2	5.3/1.8	10 x 30	1	3/1	116	2.2
SG.0.DTS.03001	3	6	11.2 x 34	1	3	94	2.7
SG.0.DTS.03002	3	6/2	11.2 x 34	1	3/1	116	2.7
SG.0.DTS.05001	5	3	11.2 x 34	2	3	108	5.4
SG.0.DTS.05002	5	3/1	11.2 x 34	2	3/1	130	5.4
SG.0.DTS.07501	7.5	2	11.2 x 34	3	3	159	8.1
SG.0.DTS.07502	7.5	2/0.6	11.2 x 34	3	3/1	184	8.1
SG.0.DTS.10001	10	3	11.2 x 34	4	2x3	219	10.8
SG.0.DTS.10002	10	3/1	11.2 x 34	4	2x3/1	263	10.8
SG.0.DTS.15001	15	2	11.2 x 34	6	2x3	262	16.2
SG.0.DTS.15002	15	2/0.6	11.2 x 34	6	2x3/1	335	16.2

* bij 50Hz / with 50Hz

Specificaties / Specifications

Voltage / Operating voltage	400-440V / 50-60Hz / 3Ph	(met elektrische loopkat alleen 400V / with electric trolley only 400V)
Hijssnelheid / Lifting speed	Enkele of dubbele snelheid / Single or double speed	
Hijsketting / Load chain	Lastketting volgens EN 818-7-DAT/DT / Load chain according to EN 818-7-DAT/DT	
Stuurkabel / Control cable	Standaard ≈6 meter / Standard ≈6 meter	
Stroomkabel / Power cable	≈1 meter zonder stekker / ≈1 meter without plug	
Behuizing bescherming / Housing protection	IP 55	
Besturing bescherming / Control protection	IP 65	
Classificatie / Classification	M5/2m (ISO/FEM)	
Inschakelduur / Starts per uur / Duty cycle / Starts per hour	40% / 240	
Isolatieklasse / Insulation class	F	
Bedrijfstemperatuur / Operating temperature	-10°C - +40°C	
Lading type / Load type	Goederen, mag niet gebruikt worden om mensen te hijsen / Goods, may not be used to lift people	



Electrische Kettingtakel SG.DTS / Electric Chain Hoist SG.DTS

Beveiliging / Protection	
Schakelaar / Control switch	24V schakelaar met noodstop / 24V pendant control switch with emergency stop button
Overlastbeveiliging / Overload protection	Extern instelbare slipkoppeling / Externally adjustable slip clutch
Rem / Brake	Elektromagnetische veerdrukkrem, houdt de lading ook bij stroomuitval stevig vast / Electromagnetic spring pressure brake, holds the load in the event of power failure
Eindschakelaar / Limit switch	Electro-mechanische hoogste en laagste eindschakelaar / Electro-mechanical upper and lower limit switch
Thermische bescherming / Thermal protection	Bescherm door warmtesensor / Protected through heat sensor

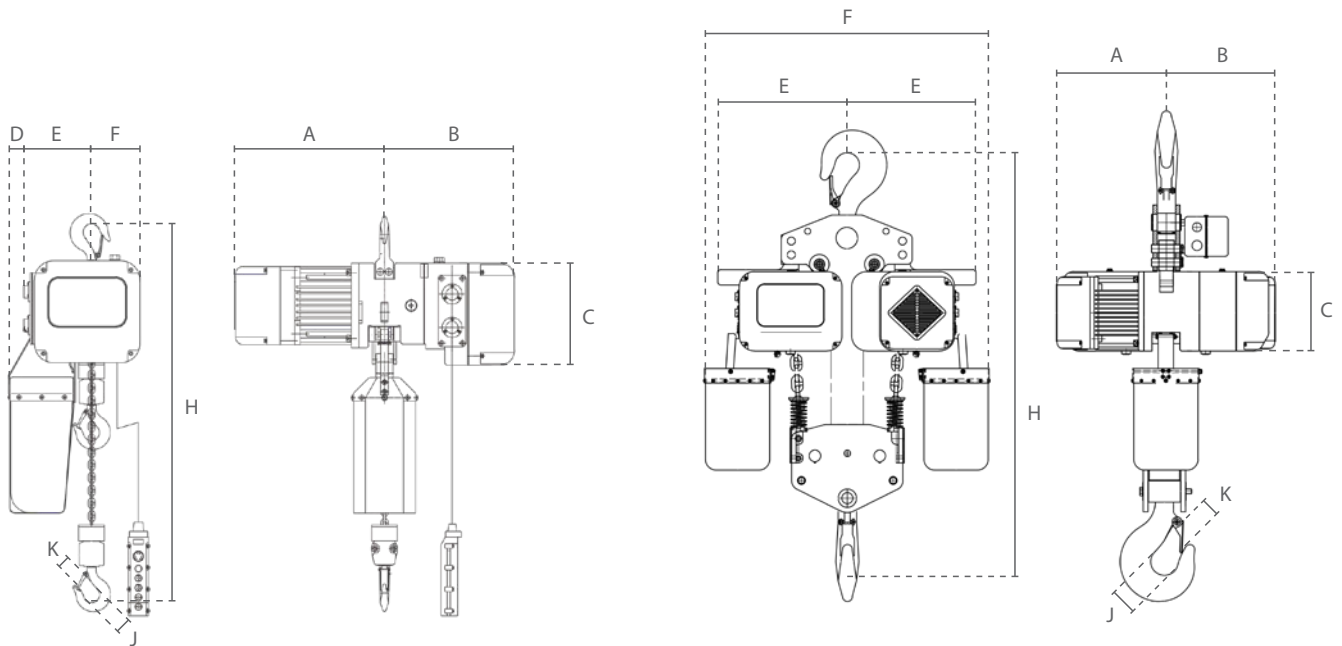

0.25 - 7.5 ton

10 - 15 ton

SG.0.DXX.XXXX1 = enkele snelheid / single speed
SG.0.DXX.XXXX2 = dubbele snelheid / double speed

Afmetingen / Dimensions										
Artikel nummer / Article code	A	B	C	D	E	F	H	J	K	
SG.0.DTS.00251	282	307	214	80	142	102	460	40	25	
SG.0.DTS.00252	307	307	214	80	142	102	460	40	25	
SG.0.DTS.00501	302	307	214	80	142	102	470	40	25	
SG.0.DTS.00502	334	307	214	80	142	102	470	40	25	
SG.0.DTS.01001	302	307	214	80	142	102	520	45	31	
SG.0.DTS.01002	354	307	214	80	142	102	520	45	31	
SG.0.DTS.02201	302	307	214	80	185	59	760	53	38	
SG.0.DTS.02202	354	307	214	80	185	59	760	53	38	
SG.0.DTS.02101	358	336	260	80	185	165	695	53	38	
SG.0.DTS.02102	481	336	260	80	185	165	695	53	38	
SG.0.DTS.03001	358	336	260	80	185	165	695	53	38	
SG.0.DTS.03002	481	336	260	80	185	165	695	53	38	
SG.0.DTS.05001	358	336	260	80	240	110	910	75	52	
SG.0.DTS.05002	481	336	260	80	240	110	910	75	52	
SG.0.DTS.07501	358	336	260	80	240	110	910	75	55	
SG.0.DTS.07502	481	336	260	80	240	110	910	75	55	
SG.0.DTS.10001	358	336	260	-	370	950	1300	80	60	
SG.0.DTS.10002	481	336	260	-	370	950	1300	80	60	
SG.0.DTS.15001	358	336	260	-	370	950	1250	112	102	
SG.0.DTS.15002	481	336	260	-	370	950	1250	112	102	



Electrische Kettingtakel SG.DTS / Electric Chain Hoist SG.DTS

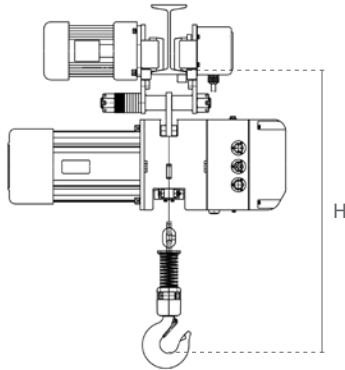

SG.0.DTD

Eigenschappen

- » Electrische kettingtakel gemonteerd op een (electrische) loopkat met een lage bouwhoogte.
- » Gebalanceerde steunwielen maken het mogelijk om soepel over de balk te bewegen.
- » Afbreukbeveiligingsbeugels dienen als val-, breek- en stootbeveiliging. Bovendien uitgerust met kantelbeveiliging.
- » Permanent gesmeerde, kogel gelagerde wielen zorgen voor een soepele verplaatsing.
- » Geschikt voor de meeste I- en H-balken.

Features

- » Electric chain hoist mounted on low headroom (electric) trolley.
- » Balance support wheels enable smooth travelling along the beam.
- » Safety bars serve as fall-, breaking- and impact protection. Additionally equipped with tilting protection.
- » Permanently lubricated, ball bearing mounted wheels allow for smooth traversing.
- » Suitable for most I- and H-beam profiles.

Specificaties / Specifications

Artikel nummer Article code	Capaciteit Capacity	Rijsnelheid Traversing speed	Energie verbruik loopkat Power output trolley	Balkbreedte Beam width	Netto gewicht Net weight	Min. hoogte (H) Min. height (H)
	ton	m/min	kW	mm	kg	mm
SG.0.DTD.00251	0.25	13.5	0.2	74-300	66	480
SG.0.DTD.00252	0.25	20/6.7	0.2/0.07	74-300	81	480
SG.0.DTD.00501	0.5	13.5	0.2	74-300	69	480
SG.0.DTD.00502	0.5	20/6.7	0.2/0.07	74-300	84	480
SG.0.DTD.01001	1	13.5	0.2	74-300	71	510
SG.0.DTD.01002	1	20/6.7	0.2/0.07	74-300	90	510
SG.0.DTD.02201	2	13.5	0.4	74-300	87	695
SG.0.DTD.02202	2	20/6.7	0.4/0.13	74-300	104	695
SG.0.DTD.02101	2	13.5	0.4	74-300	146	665
SG.0.DTD.02102	2	20/6.7	0.4/0.13	74-300	172	665
SG.0.DTD.03001	3	13.5	0.4	88-300	146	665
SG.0.DTD.03002	3	18/6	0.4/0.13	88-300	172	665
SG.0.DTD.05001	5	13.5	0.75	88-300	176	885
SG.0.DTD.05002	5	18/6	0.75/0.25	88-300	206	885
SG.0.DTD.07501	7.5	11	0.75	150-220	231	1035
SG.0.DTD.07502	7.5	11*	0.75	150-220	256	1035
SG.0.DTD.10001	10	11	0.75	150-220	341	1100
SG.0.DTD.10002	10	11*	0.75	150-220	385	1100
SG.0.DTD.15001	15	11	2x0.75	150-220	400	1250
SG.0.DTD.15002	15	11*	2x0.75	150-220	473	1250

* alleen de takel is dubbele snelheid / only the hoist is double speed



Electrische Kettingtakel SG.DTS / Electric Chain Hoist SG.DTS

Specificaties / Specifications				
Artikel nummer	Capaciteit	Balkbreedte	Netto gewicht	Min. hoogte (H)
Article code	Capacity	Beam width	Net weight	Min. height (H)
	ton	mm	kg	mm
SG.0.DTY.00251	0.25	74-300	64	480
SG.0.DTY.00252	0.25	74-300	72	480
SG.0.DTY.00501	0.5	74-300	65	480
SG.0.DTY.00502	0.5	74-300	73	480
SG.0.DTY.01001	1	74-300	67	510
SG.0.DTY.01002	1	74-300	79	510
SG.0.DTY.02201	2	74-300	73	695
SG.0.DTY.02202	2	74-300	86	695
SG.0.DTY.02101	2	88-300	136	665
SG.0.DTY.02102	2	88-300	158	665
SG.0.DTY.03001	3	88-300	136	665
SG.0.DTY.03002	3	88-300	158	665
SG.0.DTY.05001	5	88-300	152	885
SG.0.DTY.05002	5	88-300	174	885

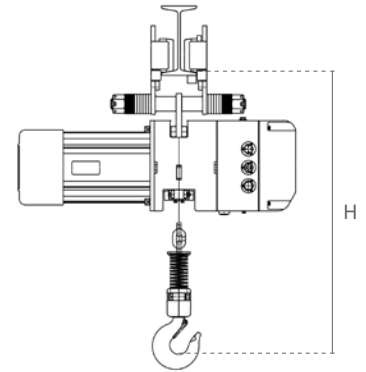

SG.0.DTY

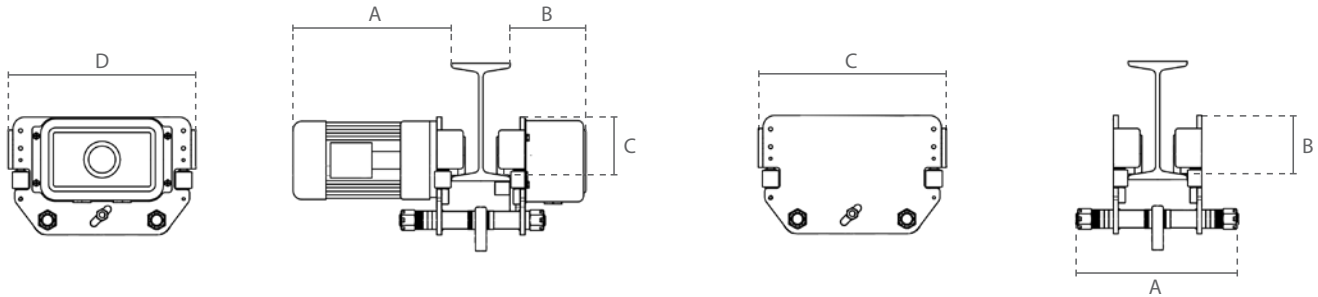

SG.0.DXX.XXXX1 = enkele snelheid / single speed
 SG.0.DXX.XXXX2 = dubbele snelheid / double speed

SG.0.DHT

SG.0.D26

Specificaties / Specifications					Afmetingen / Dimensions			
Artikel nummer	Capaciteit	Min. radius	Wiel diameter	Netto gewicht	A	B	C	D
Article code	Capacity	Min. radius	Wheel diameter	Net weight				
	ton	m	mm	kg				
SG.0.DHM.00251	0.25	2.5	68	24	296	130	97	340
SG.0.DHM.00252	0.25	2.5	68	31	336	130	97	340
SG.0.DHM.00501	0.5	2.5	68	26	296	130	97	340
SG.0.DHM.00502	0.5	2.5	68	33	336	130	97	340
SG.0.DHM.01001	1	2.5	68	26	296	130	97	340
SG.0.DHM.01002	1	2.5	68	33	336	130	97	340
SG.0.DHM.02201	2	2.5	75	36	323	132	113	340
SG.0.DHM.02202	2	2.5	75	40	338	132	113	340
SG.0.DHM.02101	2	5	96	52	325	135	133	370
SG.0.DHM.02102	2	5	96	56	340	135	133	370
SG.0.DHM.03001	3	5	96	52	325	135	133	370
SG.0.DHM.03002	3	5	96	56	340	135	133	370
SG.0.DHM.05001	5	5	110	68	360	135	140	410
SG.0.DHM.05002	5	5	110	76	410	135	140	410
SG.0.DHM.07501	7.5	2	140	72	260	170	150	400
SG.0.DHM.10001	10	3	175	122	260	170	175	500
SG.0.DHM.15001	15	5	140	138	260	170	150	900

Specificaties / Specifications					Afmetingen / Dimensions		
Artikel nummer	Capaciteit	Min. radius	Wiel diameter	Netto gewicht	A	B	C
Article code	Capacity	Min. radius	Wheel diameter	Net weight			
	ton	m	mm	kg			
SG.0.02600250	0.25	2.5	68	22	424	75	270
SG.0.02600500	0.5	2.5	68	22	424	75	270
SG.0.02601000	1	2.5	68	22	424	75	270
SG.0.02602200	2	2.5	75	22	424	75	270
SG.0.02602100	2	5	96	42	466	110	330
SG.0.02603000	3	5	96	42	466	110	330
SG.0.02605000	5	5	110	44	466	110	334



Electrische Kettingtakel SG.DTS / Electric Chain Hoist SG.DTS

SIEMENS besturingssysteem /
SIEMENS relais



Hoogste en laagste micro-eindschakelaar /
Upper and lower limit micro switch

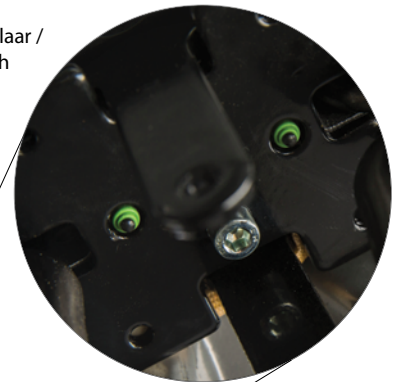

Eenvoudige plug&play-aansluitingen /
Easy plug&play connections

Hoogwaardige, duurzame ketting eindstop /
High quality, durable chain end buffer

