



## Elektrische Kettingtakel US / Electric Chain Hoist US

plug & play afstandsbediening /  
plug & play remote control

## Eigenschappen

- » Geschikt voor een breed scala aan industriële toepassingen.
- » Mag in geen service-auto ontbreken; maakt uw monteur ARBO-proof.
- » Eenvoudig te bedienen en te transporteren door zijn lage gewicht.
- » Wartel lasthaak met veiligheidsklep.
- » Geleverd klaar voor gebruik met bedieningsschakelaar, voedingskabel en kettingbak.
- » Voldoet aan de Machinerichtlijn 2006/42/EG. Geleverd met testcertificaat, CE-conformiteitsverklaring en gebruiksaanwijzing.

## Features

- » Suitable for a wide range of industrial applications.
- » Should not be missing in any service van; makes your service engineer "Health & Safety" proof.
- » Easy handling and high transportability due to low weight.
- » Swivel load hook with safety latch.
- » Supplied ready to use with control switch, power cable and chain container.
- » Complies with the Machinery Directive 2006/42/EC. Supplied with test certificate, CE declaration of conformity and operating instructions.

KARWEITAKEL®  
JOBGING HOIST®

CZ.0.US

Specificaties / Specifications							
Artikelnummer	Capaciteit	Hijssnelheid	Hijsketting	Parten	Energieverbruik	Netto gewicht	Extra gewicht
Article code	Capacity	Lifting speed	Load chain	Chain falls	Power output	Net weight	Extra weight
	ton	m/min	Øxmm		kW	kg	kg/m
CZ.0.US.901	0.5	5	6.3 x 19	1	1.3	16	0.9
CZ.0.US.902	1	2.5	6.3 x 19	2	1.3	17	1.8
CZ.0.US.903	1	4	7.1 x 20.2	1	2	26	1.1
CZ.0.US.904	2	2	7.1 x 20.2	2	2	31	2.2

Specificaties / Specifications	
Voltage / Operating voltage	230V / 50-60Hz / 1Ph (110V op aanvraag/on request)
Hijssnelheid / Lifting speed	Enkele snelheid / Single speed
Hijsketting / Load chain	Lastketting volgens EN 818-7-DAT/DT / Load chain according to EN 818-7-DAT/DT
Stuurkabel / Control cable	Standaard ≈6 meter / Standard ≈6 meter
Stroomkabel / Power cable	≈5 meter met stekker / ≈5 meter with plug
Behuizing bescherming / Housing protection	IP 54
Besturing bescherming / Control protection	IP 65
Classificatie / Classification	M4/1Am (ISO/FEM)
Inschakelduur / Starts per uur / Duty cycle / Starts per hour	30% / 180
Isolatieklasse / Insulation class	F
Bedrijfstemperatuur / Operating temperature	-10°C - +40°C
Ladingtype / Load type	Alleen voor goederen, niet geschikt om personen te hijsen / Goods, may not be used to lift people

Beveiliging / Protection	
Schakelaar / Control switch	230V schakelaar met noodstop / 230V pendant control switch with emergency stop button
Overlastbeveiliging / Overload protection	Extern instelbare slipkoppeling / Externally adjustable slip clutch
Rem / Brake	Mechanische rem / Mechanical brake
Eindschakelaar / Limit switch	US.901 + 902: Geen eindschakelaar, beveiligd door slipkoppeling / No limit switch, protected through slip clutch US.903 + 904: Elektromagnetische hoogste eindschakelaar, laagste positie beveiligd door slipkoppeling / Electromagnetic upper limit switch, lower limit protected through slip clutch
Thermische bescherming / Thermal protection	Geen bescherming / No protection



Elektrische Kettingtakel US / Electric Chain Hoist US

Optionele toebehoren / Optional accessories

alleen voor / only for US.901 & US.902



CP0.CEC.0010

10m verlengkabel / 10m extension cable

Om de stuurkabel te verlengen. (max. 2x per takel)

For extending the control cable. (max. 2x per hoist)



CZ.JACKET

Beschermhoes / Protective cover

Voor extra bescherming tegen regen.

For extra protection against rain.



CZ.BOX.US

Opbergbox / Storage box

Voor eenvoudig opslag en transport.

For convenient storage and transportation.

Netto gewicht / Net weight	Afmetingen / Dimensions
kg	mm
24	670 x 580 x 480

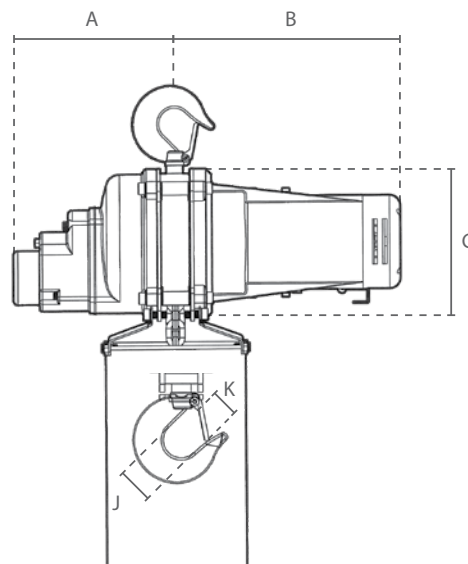
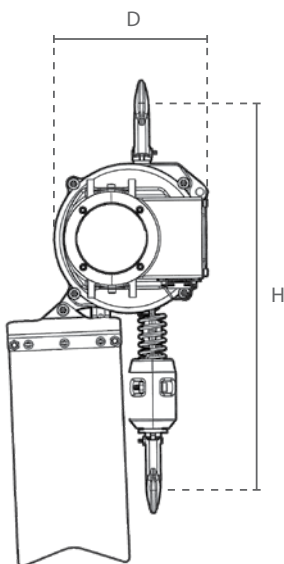

CZ.0.US.901 & 902

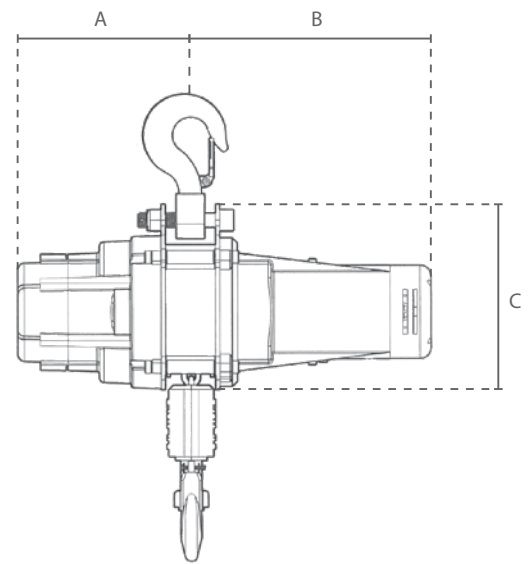

CZ.0.US.903 & 904

Afmetingen / Dimensions							
Artikelnummer / Article code	A	B	C	D	H	J	K
CZ.0.US.901	175	245	165	160	480	38	21
CZ.0.US.902	175	245	165	160	500	38	21
CZ.0.US.903	191	265	206	212	500	39	29
CZ.0.US.904	191	265	206	214	594	46	37