



Premium Elektrische Kettingtakel DEH / Premium Electric Chain Hoist DEH



Eigenschappen

- » Robuuste constructie.
- » Geschikt voor een breed scala aan industriële toepassingen.
- » Wartel lasthaak met veiligheidsklep.
- » Eenvoudig te demonteren voor onderhoudsdoeleinden.
- » Met SIEMENS / EATON besturingssysteem.
- » Permanent gesmeerde transmissie, zorgt voor een soepele en stille werking.
- » Geleverd met bedieningsschakelaar, voedingskabel en kettingbak.
- » Voldoet aan de Machinerichtlijn 2006/42/EG. Geleverd met testcertificaat, CE-conformiteitsverklaring en gebruiksaanwijzing.

Features

- » Robust housing.
- » Suitable for a wide range of industrial applications.
- » Swivel load hook with safety latch.
- » Easy to disassemble for maintenance purposes.
- » Control system with SIEMENS / EATON relays.
- » Permanently lubricated transmission, ensures smooth and quiet operation.
- » Supplied with control switch, power cable and chain container.
- » Complies with the Machinery Directive 2006/42/EC. Supplied with test certificate, CE declaration of conformity and operating instructions.



DH.0.DEH

Specificaties / Specifications							
Artikelnummer	Capaciteit	Hijssnelheid	Hijsketting	Parten	Energieverbruik	Netto gewicht	Extra gewicht
Article code	Capacity	Lifting speed	Load chain	Chain falls	Power output	Net weight	Extra weight
	ton	m/min	Øxmm		kW	kg	kg/m
DH.0.DEH.001253	0.125	8/2	4 x 12	1	0.4/0.1	22	0.4
DH.0.DEH.002503	0.25	8/2	4 x 12	1	0.4/0.1	22	0.4
DH.0.DEH.00503	0.5	8/2	5 x 15	1	0.72/0.18	33	0.7
DH.0.DEH.01003	1	8/2	7.1 x 21	1	1.6/0.4	56	1.1
DH.0.DEH.02003	2	4/1	7.1 x 21	2	1.6/0.4	58	2.2

Specificaties / Specifications	
Voltage / Operating voltage	400-440V / 50Hz / 3Ph (met elektrische loopkat alleen 400V / with electric trolley only 400V)
Hijssnelheid / Lifting speed	Dubbele snelheid / Double speed
Hijsketting / Load chain	Lastketting volgens EN 818-7-DAT/DT / Load chain according to EN 818-7-DAT/DT
Stuurkabel / Control cable	Standaard ≈6 meter / Standard ≈6 meter
Stroomkabel / Power cable	≈4.5 meter zonder stekker / ≈4.5 meter without plug
Behuizing bescherming / Housing protection	IP 55
Besturing bescherming / Control protection	IP 65
Classificatie / Classification	M5/2m (ISO/FEM)
Inschakelduur / Starts per uur / Duty cycle / Starts per hour	40% / 240
Isolatieklasse / Insulation class	F
Bedrijfstemperatuur / Operating temperature	-10°C - +40°C
Ladingtype / Load type	Alleen voor goederen, niet geschikt om personen te hijsen / Goods, may not be used to lift people

Beveiliging / Protection	
Schakelaar / Control switch	24V schakelaar met noodstop / 24V pendant control switch with emergency stop button
Overlastbeveiliging / Overload protection	Extern instelbare slipkoppeling / Externally adjustable slip clutch
Rem / Brake	Elektromagnetische veerdrukrem, houdt de lading ook bij stroomuitval stevig vast / Electromagnetic spring pressure brake, holds the load in the event of power failure
Eindschakelaar / Limit switch	Electro-mechanische hoogste en laagste eindschakelaar / Electro-mechanical upper and lower limit switch
Thermische bescherming / Thermal protection	Bescherm door warmtesensor / Protected through heat sensor



Premium Elektrische Kettingtakel DEH / Premium Electric Chain Hoist DEH



Eigenschappen

- » Elektrische kettingtakel gemonteerd op een (elektrische) loopkat met een lage bouwhoogte.
- » Gebalanceerde steunwielen maken het mogelijk om soepel over de balk te bewegen.
- » Afbreukbeveiligingsbeugels dienen als val-, breek- en stootbeveiliging. Bovendien uitgerust met kantelbeveiliging.
- » Permanent gesmeerde, kogel gelagerde wielen zorgen voor een soepele verplaatsing.
- » Geschikt voor de meeste I- en H-balken.

Features

- » Electric chain hoist mounted on low headroom (electric) trolley.
- » Balance support wheels enable smooth travelling along the beam.
- » Safety bars serve as fall-, breaking- and impact protection. Additionally equipped with tilting protection.
- » Permanently lubricated, ball bearing mounted wheels allow for smooth traversing.
- » Suitable for most I- and H-beam profiles.

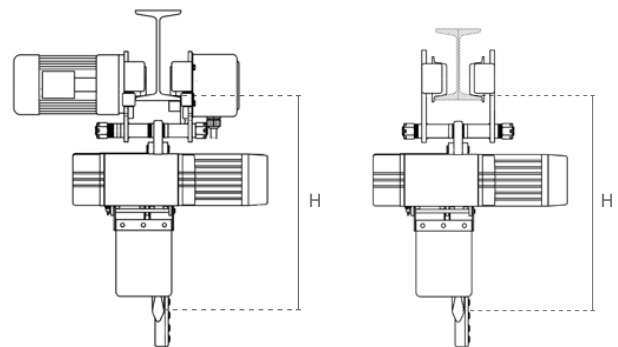

Specificaties / Specifications						
Artikelnummer	Capaciteit	Rijsnelheid	Energieverbruik loopkat	Balkbreedte	Netto gewicht	Min. hoogte (H)
Article code	Capacity	Traversing speed	Power output trolley	Beam width	Net weight	Min. height (H)
	ton	m/min	kW	mm	kg	mm
DH.0.DED.001253	0.125	20/6.7	0.2/0.07	74-300	55	438
DH.0.DED.002503	0.25	20/6.7	0.2/0.07	74-300	55	438
DH.0.DED.00503	0.5	20/6.7	0.2/0.07	74-300	66	480
DH.0.DED.01003	1	20/6.7	0.2/0.07	74-300	89	578
DH.0.DED.02003	2	20/6.7	0.4/0.13	74-300	98	670

Specificaties / Specifications				
Artikelnummer	Capaciteit	Balkbreedte	Netto gewicht	Min. hoogte (H)
Article code	Capacity	Beam width	Net weight	Min. height (H)
	ton	mm	kg	mm
DH.0.DEY.001253	0.125	74-300	29	438
DH.0.DEY.002503	0.25	74-300	29	438
DH.0.DEY.00503	0.5	74-300	40	480
DH.0.DEY.01003	1	74-300	63	578
DH.0.DEY.02003	2	74-300	70	670



Elektrische Kettingtakels / Electric Chain Hoists



Premium Elektrische Kettingtakel DEH / Premium Electric Chain Hoist DEH

NEW 2022 Eenvoudig uitwisselbare relais gemonteerd op een stalen plaat / Easily exchangeable relays mounted on a steel plate

NEW 2022 Betrouwbaar besturingssysteem / Reliable relays

- USA **EATON** 125 kg 250 kg
- GER **SIEMENS** 500 kg 1000 kg 2000 kg

NEW 2022 Eenvoudige plug&play-aansluitingen / Easy plug&play connections

NEW 2022 Hoogste en laagste micro-eindschakelaar / Upper and lower limit micro switch

NEW 2022 Hoogwaardige, duurzame kettingeindstop / High quality, durable chain end buffer

NEW 2022 2e generatie / 2nd generation -2022-



Elektrische Kettingtakels / Electric Chain Hoists



Premium Elektrische Kettingtakel DEH / Premium Electric Chain Hoist DEH

NEW 2022 Eenvoudig bereikbare en verstelbare slipkoppeling / Easily reachable and adjustable slip clutch

NEW 2022 kettinggeleider eenvoudig toegankelijk voor onderhoudsdoelinden / Chain guide easily accessible for maintenance purposes

NEW 2022 Vernieuwde verstelingsbak / Updated gearbox

NEW 2022 Vernieuwde ergonomische bediening / Updated ergonomic control

NEW 2022 Vernieuwde kettingbak / Updated chain bucket

NEW 2022 RUD® hijketting / RUD® load chain



Premium Elektrische Kettingtakel DEH / Premium Electric Chain Hoist DEH

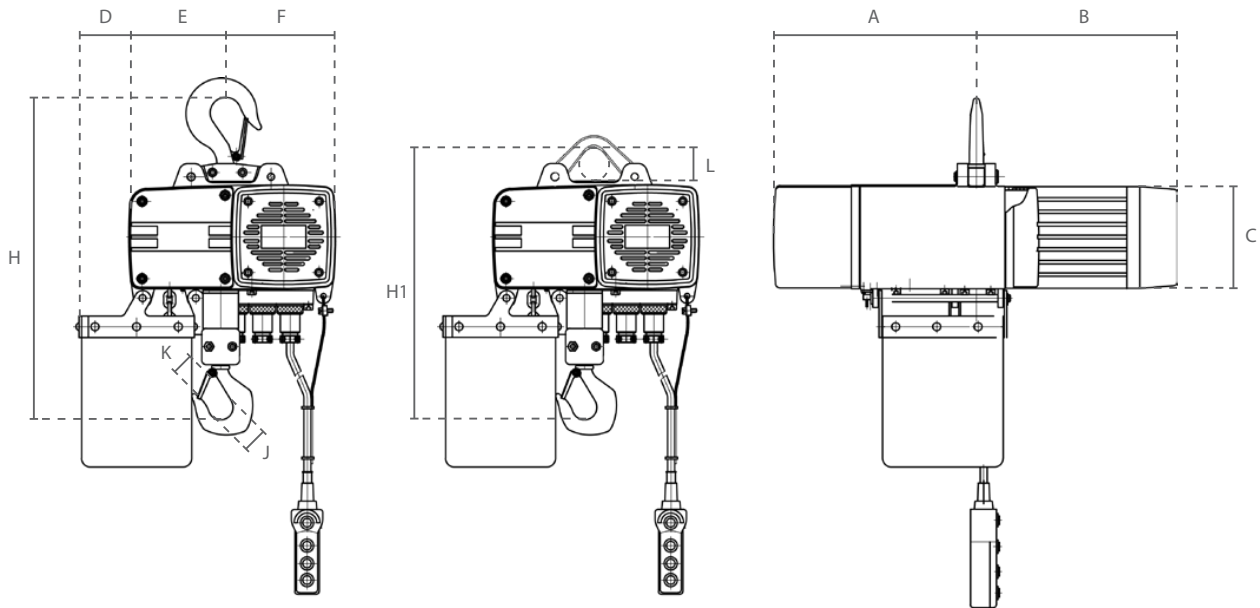

Afmetingen / Dimensions											
Artikelnummer Article code	A	B	C	D	E	F	H	H1	J	K	L
DH.0.DEH.001253	211	228	115	57	114	123	420	373	40	23	53
DH.0.DEH.002503	211	228	115	57	114	123	420	373	40	23	53
DH.0.DEH.00503	231	204	165	62	118	162	465	420	40	27	58
DH.0.DEH.01003	264	245	175	67	128	187	575	520	45	31	61
DH.0.DEH.02003	264	245	175	89	150	165	690	595	53	38	61

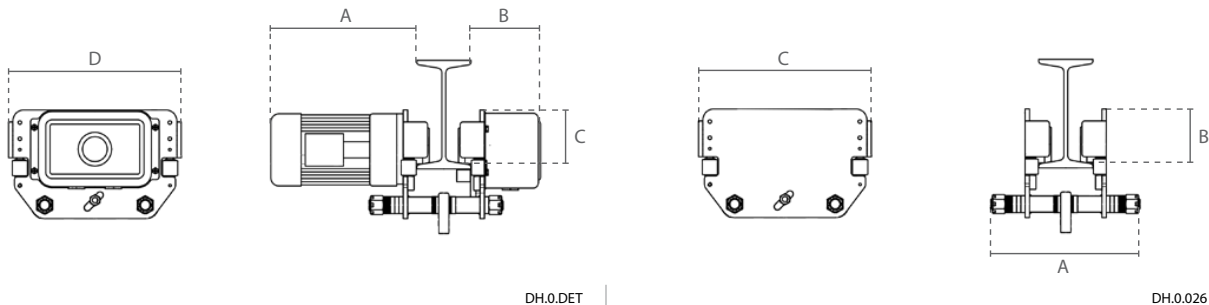

Specificaties / Specifications					Afmetingen / Dimensions			
Artikelnummer Article code	Capaciteit Capacity	Min. radius Min. radius	Wiel diameter Wheel diameter	Netto gewicht Net weight	A	B	C	D
	ton	m	mm	kg				
DF.0.DET.01252	0.125	2.5	68	33	336	131	97	320
DF.0.DET.0252	0.25	2.5	68	33	336	131	97	320
DF.0.DET.0502	0.5	2.5	68	33	336	131	97	320
DF.0.DET.1002	1	2.5	68	33	336	131	97	340
DF.0.DET.2002	2	2.5	75	40	338	132	113	340

Specificaties / Specifications					Afmetingen / Dimensions		
Artikelnummer Article code	Capaciteit Capacity	Min. radius Min. radius	Wiel diameter Wheel diameter	Netto gewicht Net weight	A	B	C
	ton	m	mm	kg			
DF.0.02600125	0.125	2.5	68	7	424	75	270
DF.0.02600250	0.25	2.5	68	7	424	75	270
DF.0.02600500	0.5	2.5	68	7	424	75	270
DF.0.02601000	1	2.5	68	7	424	75	270
DF.0.02602000	2	2.5	75	12	424	75	270