



Premium Rateltakel / Premium Lever Hoist

**Eigenschappen**

- » Onderhoudsvriendelijk ontwerp. Rem en transmissie zijn eenvoudig toegankelijk.
- » De transmissie wordt ondersteund door hoogwaardige lagers.
- » Fijn geslepen assen, nestenwiel en tandwielen zorgen voor een soepele werking.
- » Dubbele behuizing biedt bescherming tegen stof en water.
- » Robuuste behuizing is bestand tegen externe schokken zonder schade aan de uitlijning van de lagers.
- » Ergonomische hendel met rubberen handvat.
- » Geoptimaliseerde lastketting geleidingsstelsel.
- » Meetpunten op de haken.

**Premium eigenschappen:**

- » Verbeterde vrijloopmodus (trek het handwiel uit).
  - » Geen minimale belasting nodig om het ratelmechanisme te activeren.
  - » Verbeterde corrosiebestendige, gesloten lagers.
  - » Compacte hendel reduceert het gewicht geschikt voor gebruik in kleine ruimten.
  - » Gietijzeren handwiel zorgt voor betere gebruikerservaring.
- » Voldoet aan de Machinerichtlijn 2006/42/EG. Geleverd met testcertificaat, CE-conformiteitsverklaring en gebruiksaanwijzing.

**Features**

- » Maintenance friendly design. Brake and transmission are easy to access.
- » The transmission is supported by high-quality bearings.
- » Precision machined shafts, chain sprocket and gears ensure smooth operation.
- » High strength double casing provides protection against dust and water.
- » Robust housing endures external shock without damage to the bearing alignment.
- » Ergonomic lever with rubber sleeve.
- » Optimised load chain guidance system.
- » Measurement points on the hooks.

**Premium features:**

- » Enhanced free spooling mode (pull out hand wheel).
  - » No minimum preload required to activate ratchet mechanism.
  - » Enhanced corrosion resistant, caged bearings.
  - » Compact lever reduces weight and enables narrow space operation.
  - » Cast steel hand wheel provides better performance.
- » Complies with the Machinery Directive 2006/42/EC. Supplied with test certificate, CE declaration of conformity and operating instructions.



Specificaties / Specifications								
Artikelnummer	Capaciteit	Hijsketting	Parten	Test load	Inspanning voor max lading	Hendel draaiingen voor 1m hijsen	Netto gewicht	Extra gewicht
Article code	Capacity	Load chain	Chain falls	Test load	Effort for max load	Lever turns for 1m lift	Net weight	Extra weight
	ton	Øxmm		kN	N		kg *	kg/m **
DR.0.0550800	0.8	6 x 18	1	9.8	180	54	5.6	0.9
DR.0.0551600	1.6	8 x 24	1	19.6	355	63	8.5	1.5
DR.0.0553200	3.2	10 x 30	1	39.2	335	60	16.2	2.3
DR.0.0556300	6.3	10 x 30	2	77.2	350	119	21.9	4.6
DR.0.0559000	9	10 x 30	3	110.3	323	179	32.1	6.9

\* zonder lastketting / without loadchain \*\* per meter hijs hoogte / per meter hoisting height

Specificaties / Specifications	
Haken / Hooks	Gesmede stalen haken met gegoten klep / Drop-forged steel hooks with cast latch
Lastketting / Load chain	Gegalvaniseerde lastketting volgens EN 818-7-T / Galvanized load chain according to EN 818-7-T
Bedrijfstemperatuur / Operating temperature	-10°C - +60°C
ATEX zone / ATEX zone	niet geschikt / not suitable
Ladingtype / Load type	Alleen voor goederen, niet geschikt om personen te hijsen / Goods, may not be used to lift people

Beveiliging / Protection	
Overlastbeveiliging / Overload protection	Beschikbaar met slipkoppeling overlastbeveiliging / Available with slip clutch overload protection
Rem / Brake	<b>Premium eigenschap:</b> Automatische veiligheidsrem met dubbele pallen. Stalen remschijf met gesinterde remblokken voor een langere levensduur. / <b>Premium feature:</b> Automatic safety load brake with twin pawls. Extremely durable steel brake disc with sintered brake pads.



YouTube



Watch the product video!

*\* click on the link \**



Nederlands

<https://youtu.be/6VuVW9InQpw>



English

<https://youtu.be/46EVm5eUOfQ>



Deutsch

<https://youtu.be/KwpbqW9kPWE>



Français

<https://youtu.be/2wmmW9PMRnM>



Español

<https://youtu.be/8vdiekSHyyg>



Italiano

<https://youtu.be/ixYL52TzG8k>



Dansk

<https://youtu.be/1qpl5J7VVd0>



Premium Rateltakel / Premium Lever Hoist

Beschikbaar met slipkoppeling overlastbeveiliging / Available with slip clutch overload protection

Artikelnummer	Capaciteit
Article code	Capacity
	ton
<a href="#">DR.0.0520800.OP</a>	0.8
<a href="#">DR.0.0521600.OP</a>	1.6
<a href="#">DR.0.0523200.OP</a>	3.2
<a href="#">DR.0.0526300.OP</a>	6.3
<a href="#">DR.0.0529000.OP</a>	9

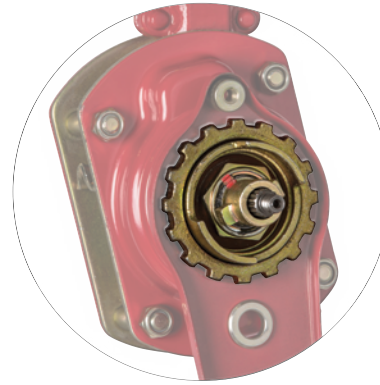

0.8 ton



1.6 ton



3.2 ton



6.3 ton



9 ton



VS



Gesloten cilinderrollagers voor intensief gebruik. / Closed heavy-duty cylindrical roller bearings.



Stalen remschijf met gesinterde remblokken voor een langere levensduur en betere prestaties. / Extremely durable steel brake disc with sintered brake pads offers high performance.



Standaard remschijf. / Standard brake disc.

Hoogwaardig gegoten veiligheidskleppen. / High-quality cast safety latches.

**Premium**



Verbeterde vrijloopmodus (trek het handwiel uit). / Enhanced free spooling mode (pull out hand wheel).

Verbeterd handwiel. / Improved hand wheel.

Geen minimale belasting nodig om het ratelmechanisme te activeren. / No minimum preload required to activate ratchet mechanism.

Compacte hendel. / Compact lever.

Beschikbaar met slipkoppeling overlastbeveiliging. / Available with slip clutch overload protection.





CE

Afmetingen / Dimensions

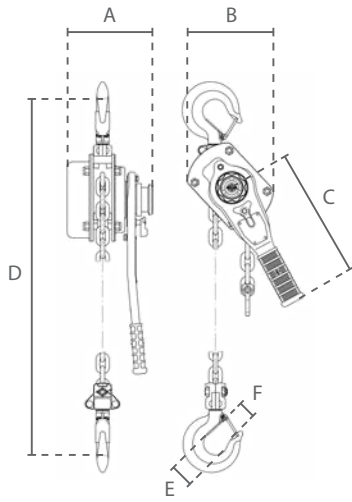

0.75 - 3 ton

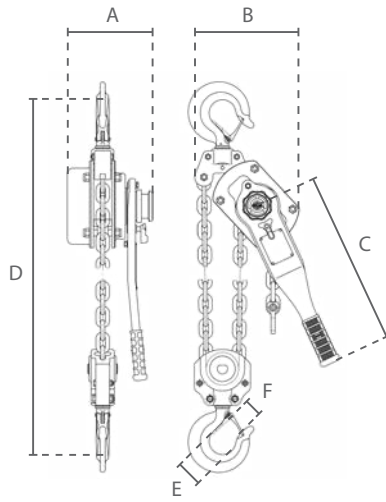

6 ton

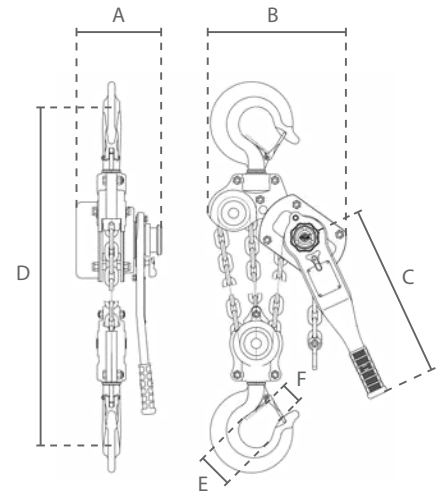

9 ton

**DELTA RED**

Capaciteit / Capacity		Afmetingen / Dimensions					
ton		A	B	C	D	E	F
0.8		160	133	250	320	38	26
1.6	30kN	182	157	270	365	48	29
3.2	60kN	208	210	430	490	58	39
6.3		208	253	430	583	65	43
9		208	338	430	830	85	58



**DELTA YELLOW**

Capaciteit / Capacity		Afmetingen / Dimensions					
ton		A	B	C	D	E	F
0.75		148	135	290	320	37	26
1.5		176	162	420	380	45	33
3		195	211	420	480	50	38
6		195	254	420	620	64	48
9		195	319	420	700	85	50

