

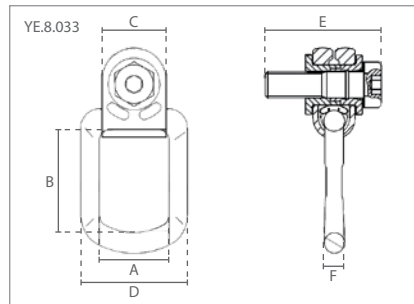

Grade 80 Toebehoren volgens EN 1677 / Grade 80 Accessories according to EN 1677

43. Wartel oogbouten /  
Swivel eye bolts



43 Specificaties / Specifications				Afmetingen / Dimensions (mm)							
Artikel nummer	Capaciteit / Capacity	Capaciteit / Capacity	Gewicht / Weight	M	A	B	C	D	E	F	
Article code	(0°) ton	(90°) ton	kg								
YE.8.033.08	0.30	0.30	0.4	M8x10	35	53	30	45	46	14	
YE.8.033.10	0.63	0.63	0.4	M10x16	35	53	30	45	52	14	
YE.8.033.12	1.00	1.00	0.7	M12x18	40	54	36	68	62	18	
YE.8.033.14	1.20	1.20	0.7	M14x21	40	54	36	68	66	18	
YE.8.033.16-030	1.50	1.50	0.7	M16x30	40	54	36	68	70	18	
YE.8.033.16-040	1.50	1.50	0.8	M16x40	40	54	36	68	80	18	
YE.8.033.16-100	1.50	1.50	1.0	M16x100	40	54	36	68	140	18	
YE.8.033.18-026	2.00	2.00	1.2	M18x26	54	80	50	83	83	16	
YE.8.033.20-030	2.50	2.50	1.2	M20x30	54	80	50	83	88	16	
YE.8.033.20-040	2.50	2.50	1.2	M20x40	54	80	50	83	98	16	
YE.8.033.20-055	2.50	2.50	1.2	M20x55	54	80	50	83	113	16	
YE.8.033.20-060	2.50	2.50	1.3	M20x60	54	80	50	83	118	16	
YE.8.033.20-100	2.50	2.50	1.3	M20x100	54	80	50	83	158	16	
YE.8.033.24-035	4.00	4.00	1.4	M24x35	54	94	50	83	95	18	
YE.8.033.24-040	4.00	4.00	1.4	M24x40	54	94	50	83	100	18	
YE.8.033.24-060	4.00	4.00	1.5	M24x60	54	94	50	83	120	18	
YE.8.033.24-080	4.00	4.00	1.5	M24x80	54	94	50	83	140	18	
YE.8.033.24-100	4.00	4.00	1.5	M24x100	54	94	50	83	160	18	
YE.8.033.27	4.00	4.00	4.2	M27x38	73	106	68	120	120	27	
YE.8.033.30-048	5.00	5.00	4.4	M30x48	73	106	68	120	132	27	
YE.8.033.30-070	5.00	5.00	4.9	M30x70	73	106	68	120	154	27	
YE.8.033.36-054	7.00	7.00	4.7	M36x54	73	106	68	120	142	27	
YE.8.033.36-062	8.00	8.00	7.6	M36x62	73	106	86	120	163	31	
YE.8.033.36-070	7.00	7.00	7.8	M36x70	73	106	68	120	158	27	
YE.8.033.42-063	15.00	15.00	12.4	M42x63	94	155	95	156	179	40	
YE.8.033.42-072	10.00	10.00	8.2	M42x72	94	141	86	156	176	31	
YE.8.033.48-074	20.00	20.00	13.0	M48x74	104	155	95	176	194	40	