



## Batterij Lier / Battery Winch



## Eigenschappen

- » Geschikt voor trekwerkzaamheden.
- » Eenvoudig te installeren voor snel gebruik.
- » Eenvoudig te bedienen en te transporteren door zijn lage gewicht en draagbare koffer.
- » Ideaal voor toepassingen zonder stroomvoorziening.
- » Batterijvermogen: 20min bij maximale belasting.
- » Geleverd met reserve batterij en oplader.
- » Geleverd klaar voor gebruik met bedieningsschakelaar, staalkabel met haak, klapblock en gereedschap.
- » Voldoet aan de Machinerichtlijn 2006/42/EG. Geleverd met testcertificaat, CE-conformiteitsverklaring en gebruiksaanwijzing.

## Features

- » Suitable for pulling applications.
- » Fast installation.
- » Easy handling and high transportability due to low weight and carrying case.
- » Ideal for applications without power supply.
- » Battery power: 20min at maximum load.
- » Delivered with spare battery and charger.
- » Supplied ready to use with control switch, steel cable with load hook, pulley hook and tools.
- » Complies with the Machinery Directive 2006/42/EC. Supplied with test certificate, CE declaration of conformity and operating instructions.

## Specifications / Specifications

Artikelnummer	Capaciteit	Trekcapaciteit	Trekbereik	Max. treksnelheid	Staaldraad	Energieverbruik	Gewicht
Article code	Capacity	Pulling capacity	Pulling range	Max. pulling speed	Steel cable	Power output	Weight
	ton	ton	m	m/min	m x Ømm	kW	kg
CZ.0.DBW.350	0.14	0.35	13	4	15 x 5	0.28	8.2

## Specifications / Specifications

Toepassing / Application	Treklier / Pulling winch
Voltage / Operating voltage	18V oplaadbare li-ion batterij / 18V rechargeable li-ion battery
Treksnelheid / Pulling speed	Enkele snelheid / Single speed
Kabel / Cable	Staalkabel / Steel cable
Stuurkabel / Control cable	Standaard ≈3 meter / Standard ≈3 meter
Stroomkabel / Power cable	-
Behuizing bescherming / Housing protection	IP 54
Besturing bescherming / Control protection	IP 50
Classificatie / Classification	M4/1Am (ISO/FEM)
Inschakelduur / Starts per uur / Duty cycle / Starts per hour	25% / 180
Isolatieklasse / Insulation class	F
Bedrijfstemperatuur / Operating temperature	-10°C - +40°C
Ladingtype / Load type	Alleen voor goederen, niet geschikt om personen te hijsen / Goods, may not be used to lift people

## Beveiliging / Protection

Schakelaar / Control switch	Schakelaar met noodstop / Pendant control switch with emergency stop button
Overlastbeveiliging / Overload protection	Digitale beveiliging / Digital protection
Rem / Brake	Mechanische rem, bereikt onmiddellijk remeffect en houdt de lading ook bij stroomuitval stevig vast / Mechanical brake, achieves immediate braking and holds the load in the event of power failure
Eindschakelaar / Limit switch	Geen eindschakelaar / No limit switch



Batterij Lier / Battery Winch

Draagkoffer / Carrying case		
Capaciteit	Totale gewicht *	Afmetingen
Capacity	Total weight *	Dimensions
ton	kg	mm
0.35	16.8	690 x 440 x 170

\* inclusief alle accessoires / including all accessories

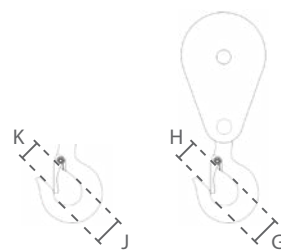
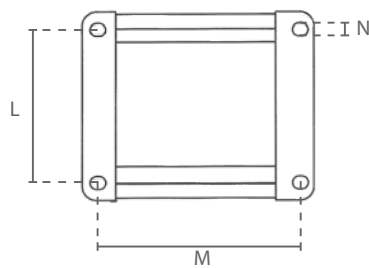
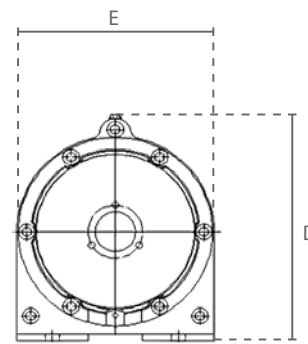
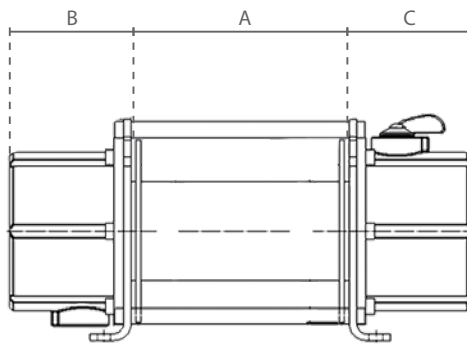

Artikelnummer Article code	Afmetingen / Dimensions											
	A	B	C	D	E	G	H	J	K	L	M	N
CZ.0.DBW.350	89	135	118	143	122	26	21	33	26	75	150	8