

AIR CHAIN HOIST

TCS-500

WLL	Lifting speed with load	Lifting speed without load	Lowering speed with load	Air consumption lifting	Air consumption lowering	Air connection
500 kg	17 m/min	33 m/min	34 m/min	28 l/sec	33 l/sec	1/2" BSPT

Minimum hose diam.	Chain falls	Chain size mm	Working pressure	Weight with 3 m hol	Additional meter hol	-
1/2" hose	1	6,3 x 19,1 RTS	6 bar	19 kg	0,8 kg	-

Information subject to change without notice

DIMENSIONS IN MM

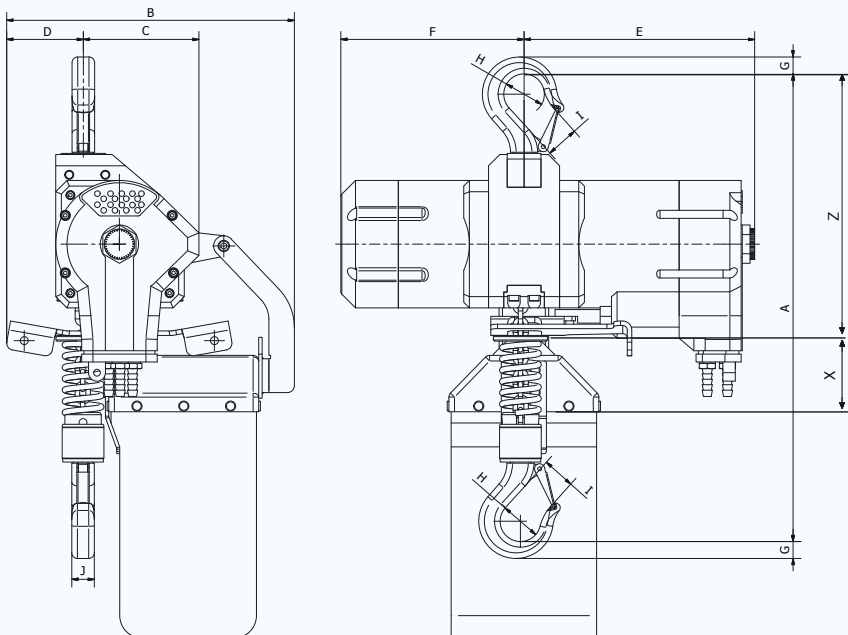

A	B	C	D	E	F	G	HØ	I	J	X	Z
415	255	103	68	205	163	15	35	22	22	40	210

All measurements are in mm / Information subject to change without notice

